

RoHS

产品料号编码说明:

C1018-08-XXXXR0

- Mark
- 0:代表“0”
- 包装类型
- R: REEL T: TUBE
- 塑胶材质
- L: LCP
- P: PA9T
- 颜色
- 1: 米黄色/黑色
- 2: 黑色/黑色
- 3: 黑色/米黄色
- 电镀类型
- 1: 电镀雾锡120u" Min
- 2: 镀金6u" Min
- 3: 镀金3u" Min
- 4: 镀金5u" Min
- 5: 镀金10u" Min
- 6: 镀金15u" Min
- 08 Pin
- 1.0mm Pitch FPC H=1.75mm CONNECTOR
- 成品类

1. MATERIAL:
 - HOUSING: LCP UL 94V-0 COLOR IS BEIGE OR BLACK
 - ACTUATOR: LCP UL94V-0 COLOR IS BLACK OR BEIGE
 - CONTACTS: COPPER ALLOY
 - PEG: COPPER ALLOY
2. PLATING:
 - 2.1 CONTACT AREA:
 - 100~200u" MATT TIN PLATING ON CONTACT AREA
 - 50~100u" NICKEL UNDER PLATING OVER ALL.
 - 2.2 SOLDER AREA:
 - 100~200u" MATT TIN PLATING ON CONTACT AREA
 - 50~100u" NICKEL UNDER PLATING OVER ALL.
- 2.3 FITTING:
 - 100~200u" MATT TIN PLATING ON SOLDER TAILS(LEAD FREE)
 - 50~100u" NICKEL UNDER PLATING OVER ALL.
3. PART NO
 - OPERATING VOLTAGE: 50V AC,DC
 - CURRENT RATING: 0.3A AC,DC
 - OPERATING TEMPERATURE: -25°C~+85°C

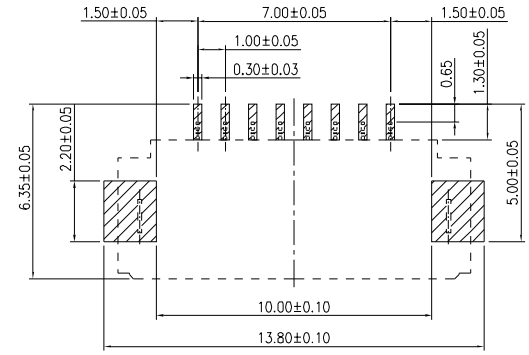

RECOMMENDED PCB LAYOUT
GENERAL TOLERANCE ±0.05 / T=0.12

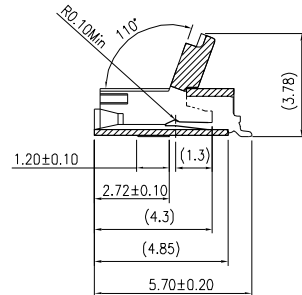
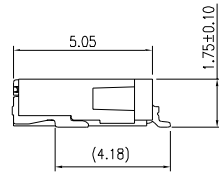
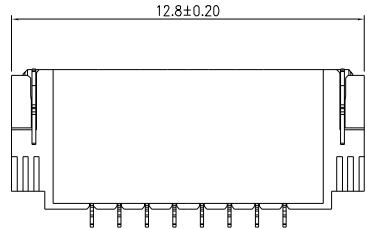
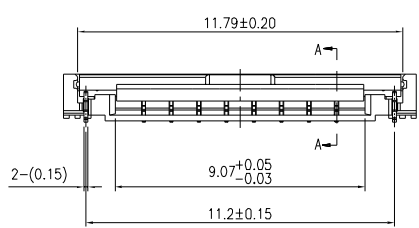
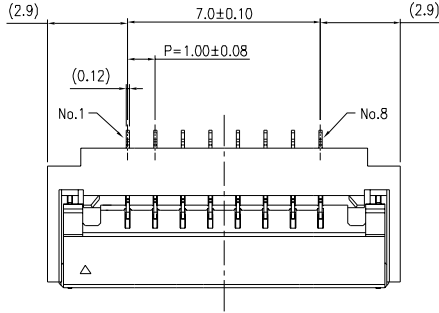

SECTION: A-A

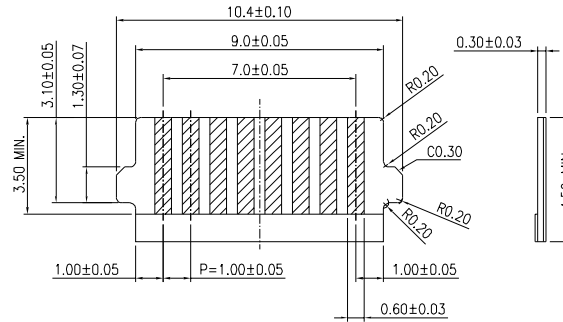

FFC SPEC
公差: ±0.05

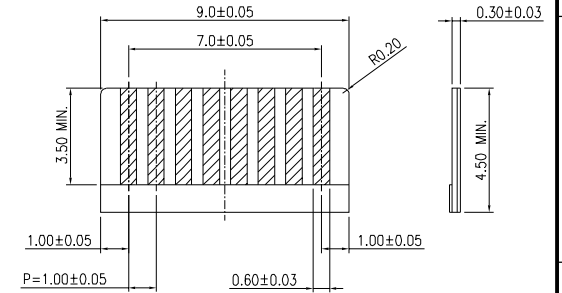

FFC SPEC
公差: ±0.05



广东国连电子有限公司
GUANGDONG GUOLIAN ELECTRONICS CO., LTD

| | | | | | | |
|-------------------|------------|------------------|--------------------|-------------------|-------------------------------------------|-----------------|
| GENERAL TOLERANCE | | UNIT: mm | DRAWN: Jenply | DATE: 2022. 2. 28 | ITEM: FPC 1.0mm Pitch H=1.75 CONNECTOR | TITLE: |
| .X ±0.5 | X.° ±2° | SCALE: 1:1 | CHECK: Jenply | DATE: 2022. 2. 28 | | |
| .XX ±0.2 | .X° ±1° | SIZE: A4 | APPROVE: Yong Xing | DATE: 2022. 2. 28 | PART NO: C1018-08-XXXXR0 | DRAWING NUMBER: |
| .XXX ±0.05 | .XX° ±0.5° | ANGLE PROJECTION | | | | |

1

2

3

由Autodesk教育版产品制作

6

7

8